

# AL430

ARTICULATED LOADER

GEHL®



## KEY FEATURES

- 4-Post Open Canopy ROPS and FOPS Certified
- Front Auxillary Hydraulics w/ Flat-Faced Couplers
- Inching Pedal
- Digital Display with Audible and Visual Indicators
- Automotive Style Hydrostatic Drive, 2-Speed
- Perkins Turbo Charged Diesel Engine
- Deluxe, Tilttable Steering Column
- Multi-Function Joystick

# AL430 ARTICULATED LOADER

## SPECIFICATIONS

		IMPERIAL	METRIC	
DIMENSIONS	A	Overall Length w/ Bucket Level	168.5" 4279 mm	
	B	Overall Length - Less Bucket	141.1" 3583 mm	
	C	Front Wheel Center to Hinge Pin - Arm Down	26.3" 669 mm	
	D	Wheel Base	65" 1650 mm	
	E	Rear Overhang	44.1" 1120 mm	
	F	Overall Height @ ROPS	88.9" 2258 mm	
	H	Height to Top of Hood	55.3" 1405 mm	
	J	Overall Operating Height - Fully Raised, Bucket Rolled Back	145.5" 3696 mm	
	K	Height to Hinge Pin - Fully Raised	114.2" 2900 mm	
	L	Ground Plane to Bucket Edge Height	104.9" 2665 mm	
	M	Dump Height - Fully Raised	85.4" 2170 mm	
	N	Dump Reach - Fully Raised	18.9" 479 mm	
	O	Digging Position (+Above Ground / -Below Ground)	3.1" 79 mm	
	P	Overall Width - Less Bucket	43.3" 1100 mm	
	Q	Track or Tread Width (Wheel Center)	32.9" 836 mm	
	R	Widest Fixed Point on Machine (ROPS width)	39" 991 mm	
	S	Ground Clearance	12.6" 320 mm	
	T	Clearance Radius - Front w/ Bucket @ Carry Position	127.8" 3246 mm	
	U	Clearance Radius - Less Bucket	108.9" 2767 mm	
	V	Clearance Radius - Inner	63.9" 1623 mm	
	W	Max Articulation Angle	45°	
	X	Maximum Rollback Angle - Fully Raised	48°	
	Y	Dump Angle - Fully Raised	42°	
	Z	Maximum Rollback Angle @ Ground	49°	
	AA	Quick-Attach Hinge Pin Ground Clearance (Pin Center)	6.7" 170 mm	
	BB	Height from Ground to Axle Center	8.4" 214 mm	
CC	Bucket Width	59.8" 1520 mm		
	Maximum Oscillation Angle	10°		
CAPACITIES	Static Tipping Load with Bucket Straight		3693 lbs 1675 kg	
	Static Tipping Load with Bucket Full Turn		3241 lbs 1470 kg	
	Static Tipping Load with Forks Straight		2789 lbs 1265 kg	
	Static Tipping Load with Forks Full Turn		2447 bs 1110 kg	
	Bucket Breakout		4442 lbs 2015 kg	
	Travel Weight With Canopy		5106 lbs 2316 kg	
ENGINE	Engine Manufacturer		Perkins	
	Model / Number of Cylinders		403J-E17T / 3	
	Power @ 2200 rpm		48.3 hp 36 kW	
	Maximum Torque / Engine Rotation @ 1600 rpm		122.4 ft/lbs 166 Nm	
HYDRAULICS	Work Hydraulic System Flow		15.8 gpm 60 lpm	
	Drive Hydraulic System Pressure		3002 psi 207 bar	
OTHER	Travel Speeds		12.4 / 17.5 mph 20 / 28 km/hr	
	Fuel Tank Capacity		13.2 gal 50 L	
	Tires		US 33 x 15.5 - 16.5 EU 15.0 x 55 - 17	

## STANDARD FEATURES

- Automotive Style Hydrostatic Drive, 2-Speed, 12.4mph (20 km/hr)
- Counterweight
- Front/Rear Tie Downs
- Heavy-Duty Axles
- Steering/Frame Transport Lock
- Deluxe Instrument Panel
- Battery Disconnect
- Perkins Turbo Charged Diesel Engine
- Lockable Engine Cover
- Radiator/Hydraulic Cooler - Side By Side
- Front Auxillary Hydraulics w/ Flat-Faced Couplers
- Adjustable Seat - 5-Way
- Adjustable Seat Belt 2 in. (50 mm)
- Braking/Inching Pedal
- Deluxe, Tilttable Steering Column
- Horn
- Multi-Function Joystick

## OPTIONAL FEATURES

- Cabin with Heat and/or Air Conditioning
- Differential Locking
- 30 km/hr max. speed
- Air suspension seat
- LED Work Lights
- LED Road Lights
- Different wheel options
- Side gates

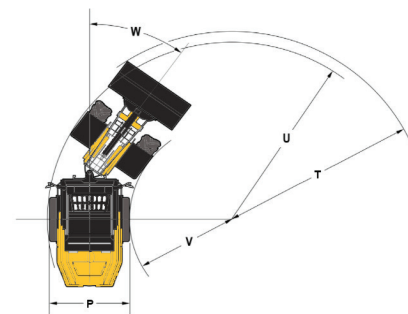
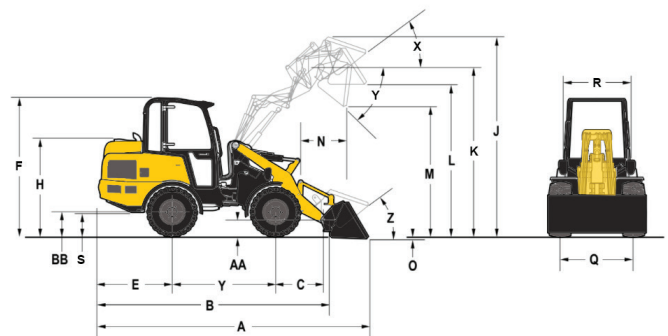

GEHL COMPACT EQUIPMENT

West Bend, WI 53095 U.S.A. | Tel: 262-334-9461 | Fax: 262-338-7517

GEHL Company reminds users to read and understand the operator's manual before operating any equipment. Also, make sure all safety devices and shields are in place and functioning properly.

GEHL reserves the right to add improvements or make changes in specifications at any time without notice or obligation